

931A, 931B

Photomultiplier

28-mm (1-1/8 inch) Diameter 9-Stage,
Side Window PMTs

- Anti-Hysteresis Design
- Narrow Range of Anode Sensitivities
931A: 30 A/lm - 600 A/lm
931B: 100 A/lm - 1000 A/lm
- Low Dark Current

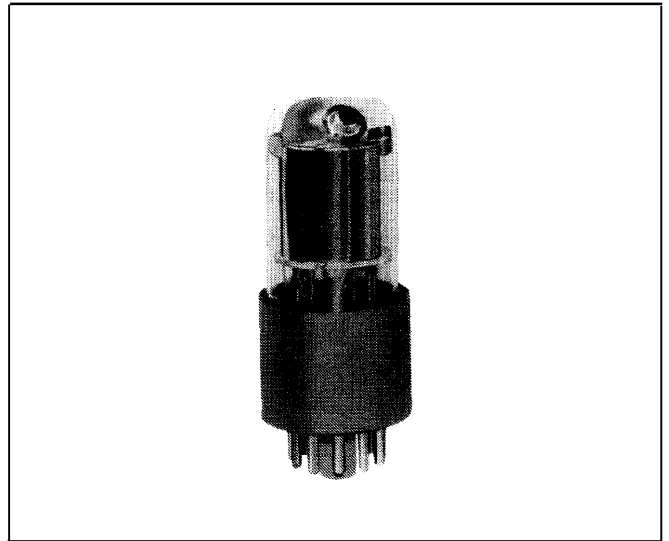

BURLE 931A is a 9-stage, side-window type of photomultiplier tube intended for general purpose applications in low-light level detection and measurement systems. It features a circular-cage with electrostatically focussed dynodes and fast time resolution characteristics.

BURLE 931B is a 9-stage, side-window type of photomultiplier tube intended for general purpose applications in low light level detection and measurement systems. It features a circular-cage with electrostatically focussed dynodes, and fast time resolution characteristics. Typically, the 931B offers higher photocathode quantum efficiency, higher anode sensitivity, and lower dark current than the 931A. The 931B also features an anode current drift rating which limits variations in anode current to a maximum of $\pm 2\%$.

GENERAL DATA

Photocathode Spectral Response.....	See Figure 1
Wavelength of maximum response.....	380 nm
Window Material ¹	Corning No. 0080, or Equivalent
Index of refraction @ 436 nanometers.....	1.523
Projected Cathode Minimum Dimensions:²	
Length.....	23.9 mm (0.94 in)
Width.....	7.9 mm (0.31 in)
Dynodes:	
Secondary-Emitting Surface.....	Cs-Sb
Structure.....	Circular-Cage, Electrostatic-Focus
Direct Interelectrode Capacitances (Approx.):	
Anode to dynode no. 9.....	4.4 pF
Anode to all other electrodes.....	6.0 pF
Anode Pulse Rise Time, 1000 V ³	1.8 ns
Electron Transit Time, 1000 V ⁴	18.0 ns
Base.....	JEDEC B11-88, Non-Hygroscopic
Socket.....	BURLE AJ2256
Magnetic Shield.....	BURLE AJ2240
Operating Position.....	Any
Weight (Approx.).....	45 g (1.6 oz.)

ABSOLUTE MAXIMUM RATINGS

DC Supply Voltage:	
Between anode and cathode.....	1250V
Between anode and dynode no. 9.....	250 V
Between adjacent dynodes.....	250V
Between dynode no. 1 and cathode.....	250V
Average Anode Current ⁵	1.0 mA
Temperature: ⁶	
Operating and storage.....	-80 to +70 °C

PERFORMANCE DATA

Under conditions with dc supply voltage (E) across a voltage divider providing 1/10 of E between cathode and dynode no. 1; 1/10 of E for each succeeding dynode stage; and 1/10 of E between dynode no. 9 and anode. Ambient temperature is 22 °C.

With E = 1000 volts (except as noted). See Table 1.

931A PHOTOMULTIPLIER

	Min.	Typ.	Max.	
Anode Responsivity:				
Radiant @ 380 nm.....	-	2.1x10 ⁵	--	A/W
Luminous ⁷	30	300	600	A/lm
Cathode Responsivity:				
Radiant @ 380 nm.....	-	38	--	mA/W
Luminous ⁸	25	55	--	μA/lm
Current Amplification (Gain) ..	--	5.5x10 ⁶	--	
Anode Dark Current ⁹	-	6	150	nA

931B PHOTOMULTIPLIER

	Min.	Typ.	Max.	
Anode Responsivity:				
Radiant @ 380 nm.....	-	3.4x10 ⁵	--	A/W
Luminous ⁷	100	360	1000	A/lm
Cathode Responsivity:				
Radiant @ 380 nm.....	--	56	--	mA/W
Luminous ⁸	40	60	--	μA/lm
Current Amplification (Gain) ..	--	6x10 ⁶	--	
Anode Dark Current ⁹	--	2	40	nA
Anode Current Drift ¹⁰	--	1	2	%

NOTES

1. Made by Corning Glass Works, Corning, NY 14830.
2. On plane perpendicular to the indicated direction of incident light and passing through the major axis of the tube.
3. Measured between 10 percent and 90 percent of maximum anode-pulse height. This anode-pulse rise time is primarily a function of transit time variation and is measured under conditions with the incident light fully illuminating the photocathode.
4. The electron transit time is the time interval between the arrival of a delta function light pulse at the entrance window of the tube and the time at which the output pulse at the anode terminal reaches peak amplitude. The transit time is measured under conditions with the incident light fully illuminating the photocathode.
5. Averaged over any 30 seconds interval.
6. Tube operation at room temperature or below is recommended.
7. Under the following conditions: The light source is a tungsten-filament lamp having a lime-glass envelope. The lamp is operated at a color temperature of 2856 degrees K and a light flux of 1×10^{-6} lumen is used.
8. Under the following conditions: The light source is a tungsten-filament lamp having a lime-glass envelope. The lamp is operated at a color temperature of 2856 degrees K and a light flux of 1×10^{-6} lumen is used. 100 volts are applied between cathode and all other electrodes connected as anode.
9. At a tube temperature of 22 degrees C. The supply voltage is adjusted to 1000 volts. Dark current is measured with the light source removed.
10. Anode current drift is measured under the following conditions: The tube is operated at a supply voltage of 1000 volts for 30 minutes with the incident light level adjusted initially to provide an anode current (Ib) of 3.0 microamperes. The change in anode current for the next 12 minutes is continuously recorder and must not vary by more than the value specified. Anode current drift is defined as follows:

$$\text{Anode Current Drift} = \frac{I_{b1} \text{ (30 to 42 minutes)}}{I_b \text{ (at 30 minutes)}}$$

where I_{b1} = the incremental change in anode current.

TABLE 1

Voltage Distribution	
Between the Following Electrodes: K = Cathode P = Anode Dy = Dynode	10.0% of K-P Voltage Multiplied By:
K-Dy1	1
Dy 1 - Dy2	1
Dy 2 - Dy 3	1
Dy 3 - Dy 4	1
Dy 4 - Dy 5	1
Dy 5 - Dy 6	1
Dy 6 - Dy 7	1
Dy 7 - Dy 8	1
Dy 8 - Dy 9	1
Dy 9 - P	1
K - P	10

OPERATING CONSIDERATIONS

Unless otherwise stated the operating conditions discussed in the following paragraphs apply to both the 931A and the 931B.

OPERATING STABILITY

The operating stability of the photomultipliers is dependent on the magnitude of the anode current. The use of an average anode current well below the maximum rated value of 1.0 milliampere is recommended when stability of operation is important. When maximum stability is required, operation at an average current of 1.0 microampere or less is suggested.

AMBIENT ATMOSPHERE

Operation or storage of these tubes in environments where helium is present should be avoided. Helium may permeate the tube envelope and may lead to eventual tube destruction.

TUBE ORIENTATION

The responsivity of the photocathode surface varies with respect to the position of the light spot on the surface. **Figure 4** shows the variation in responsivity of the surface as the position of a 1-mm diameter light spot is moved from one end of the photocathode to the other. Similarly, the curve in **Figure 5** shows how the responsivity of the photocathode surface varies across its projected width in the plane of the grill. From these curves the equipment designer can readily determine the optimum position of any light spot on the photocathode surface to give the highest responsivity.

When an application involves use of light flux which covers essentially the entire cathode area, consideration should be given to the effect on luminous responsivity caused by angular position of the photocathode with respect to the direction of incident light. This effect is shown in **Figure 6**. As the tube is rotated from the position of maximum responsivity (approximately + 13 degrees as shown in **Figure 6**) the internal structure prevents portions of a large beam of light from striking the cathode. With a light spot covering only a small portion of the cathode area, relatively minor cutoff of light occurs making the directional effect on luminous responsivity very small.

SHIELDING

Electrostatic and/or magnetic shielding of the photomultipliers may be necessary. An external electrostatic shield, in contact with the sides of the glass envelope and connected to a negative dc potential essentially the same as that of the photocathode, should be employed in those applications where it is desired to reduce the equivalent noise input of the tube to a minimum.

It is noted that the use of an external magnetic and/or electrostatic shield at high negative potential presents a safety hazard unless the shield is connected through a high impedance in the order of 10 megohms to the negative potential source. If the shield is not so connected, extreme care should be observed in providing adequate safeguards to prevent personnel from coming into contact with the high potential of the shield.

Magnetic shielding of the photomultiplier is necessary if it is operated in the presence of strong magnetic fields. With increase in supply voltage between anode and cathode, the effect of a given magnetic field will cause less decrease in anode current.

Adequate light shielding should be provided to prevent extraneous light from reaching any part of the tube.

DARK CURRENT

The use of a refrigerant, such as dry ice, to cool the tube is recommended in those applications where

maximum current amplification with minimum dark current is required.

Typical anode dark current and EADCI as a function of luminous responsivity at a temperature of +22 degrees C are shown in **Figures 7 and 8.**

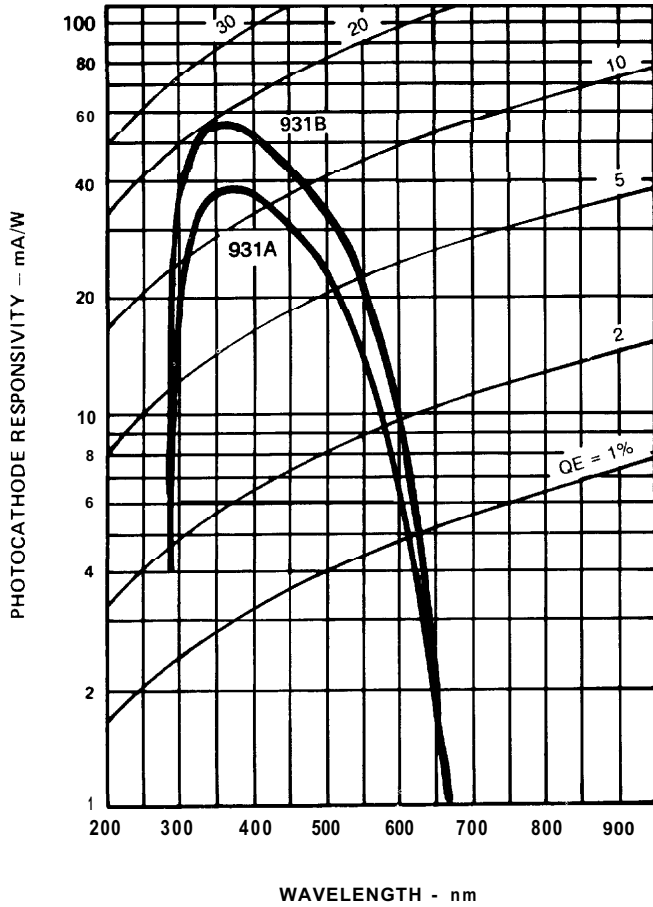

Figure 1 - Typical Photocathode Spectral Response Characteristics

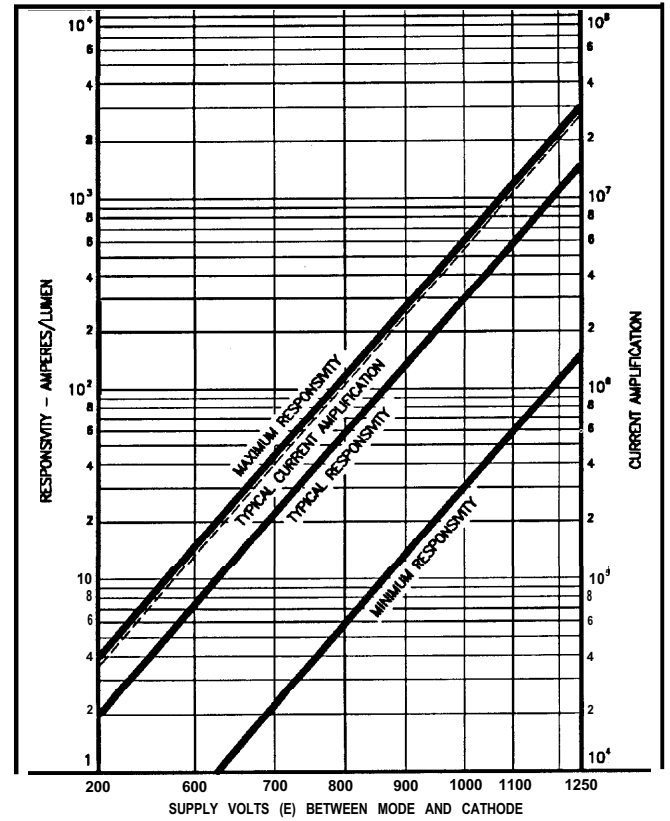

Figure 2 - Typical Current Amplification and Responsivity Characteristics - Type 931A

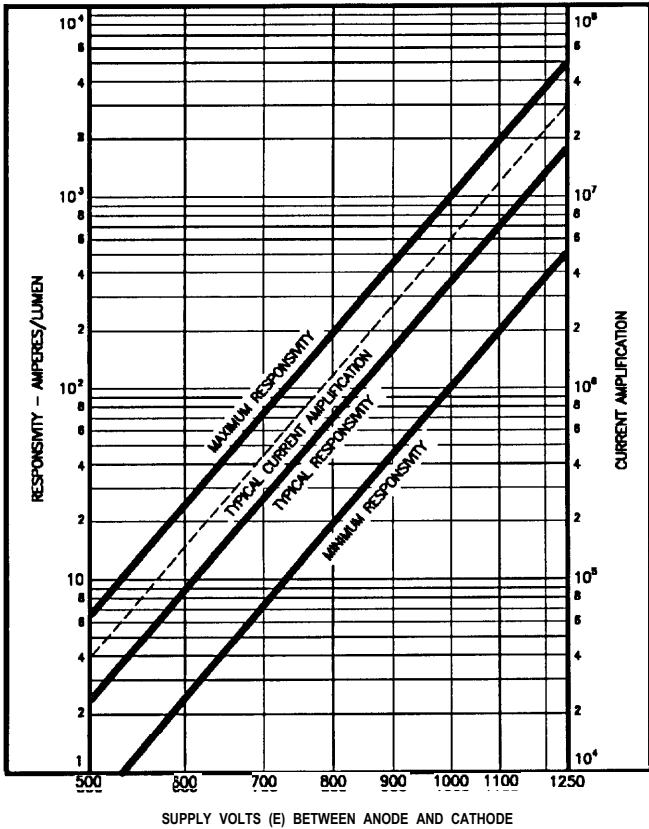

Figure 3 - Typical Current Amplification and Responsivity Characteristics - Type 931 B

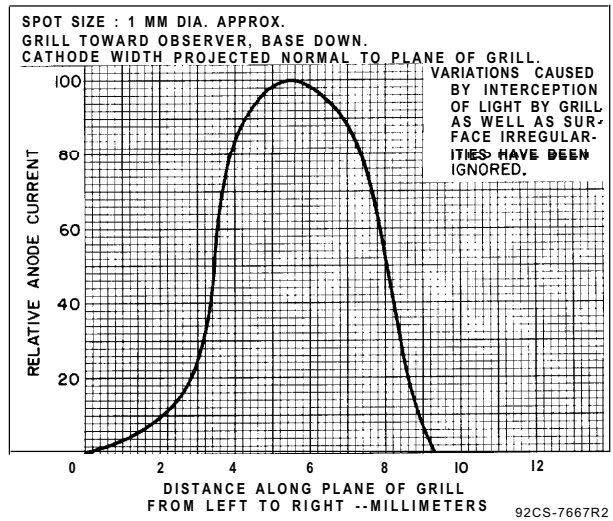

Figure 5 - Typical Variation of Photocathode Sensitivity Across Projected Width in Plane of Grill

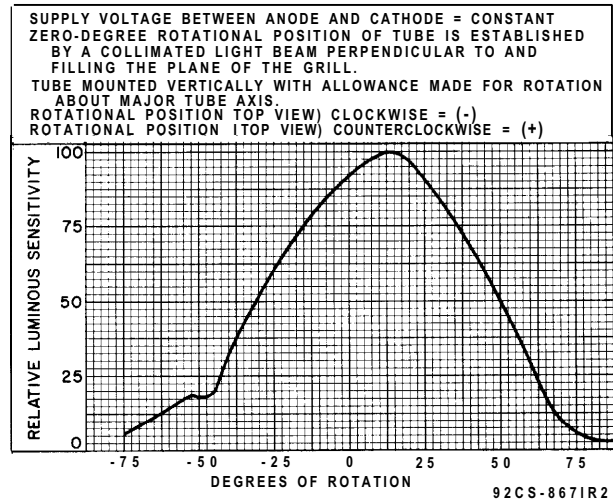

Figure 6 - Typical Variation of Responsivity as Tube is Rotated with Respect to Fixed Light Beam

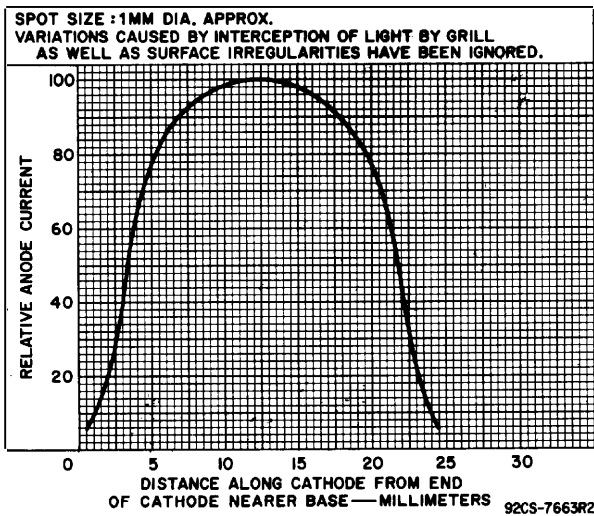

Figure 4 - Typical Variation of Photocathode Sensitivity Along Tube Length

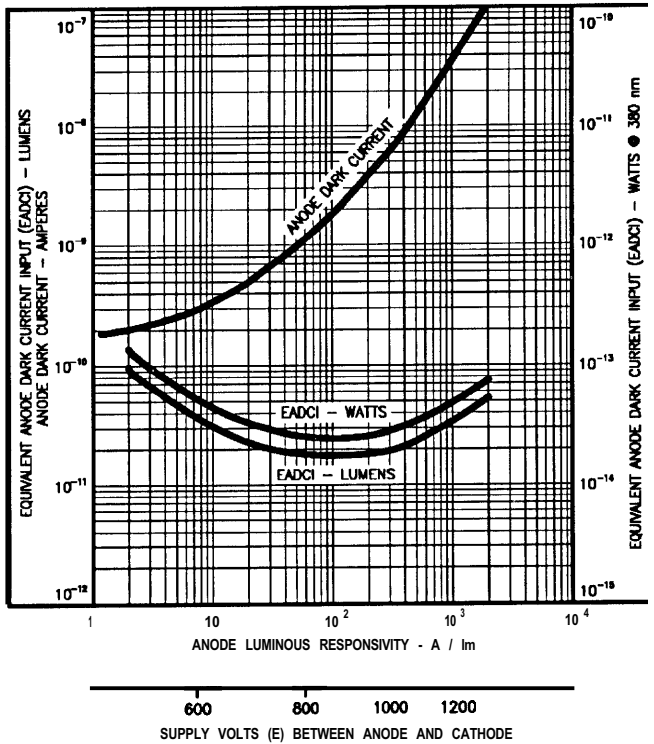

Figure 7 - Typical EADCI and Dark Current Characteristics - Type 931A

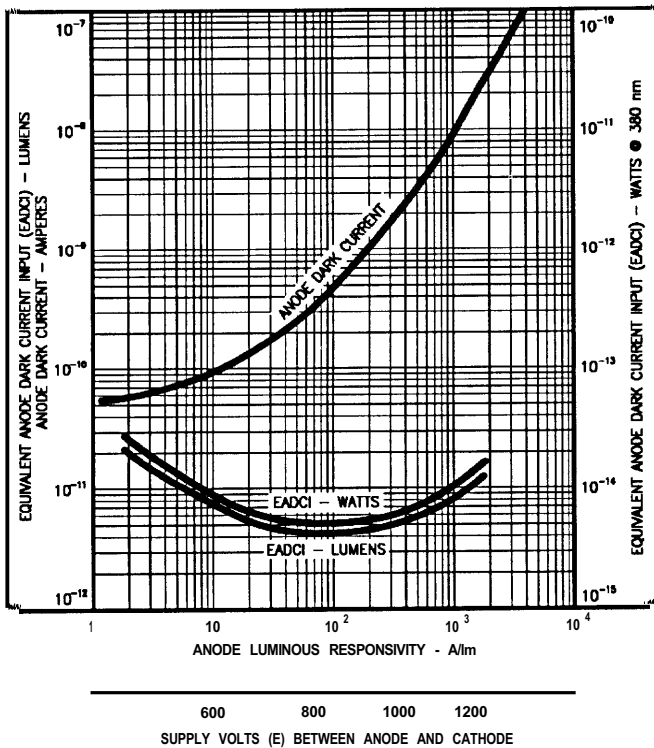
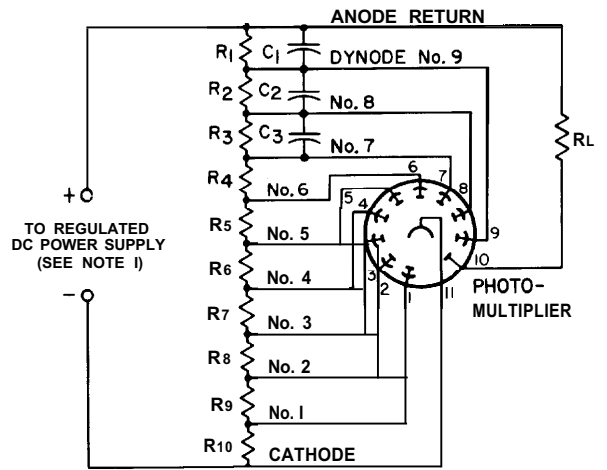

Figure 8 - Typical EADCI and Dark Current Characteristics - Type 931 B



92CS-II382R2

R_1 through R_{10} = 20,000 to 1,000,000 ohms.

Note 1: Adjustable between approximately 500 and 1250 volts.

Note 2: Capacitors C_1 through C_3 should be connected at tube socket for optimum high-frequency performance. The capacitors are not required for dc applications.

Figure 9 - Typical Voltage-Divider Arrangement

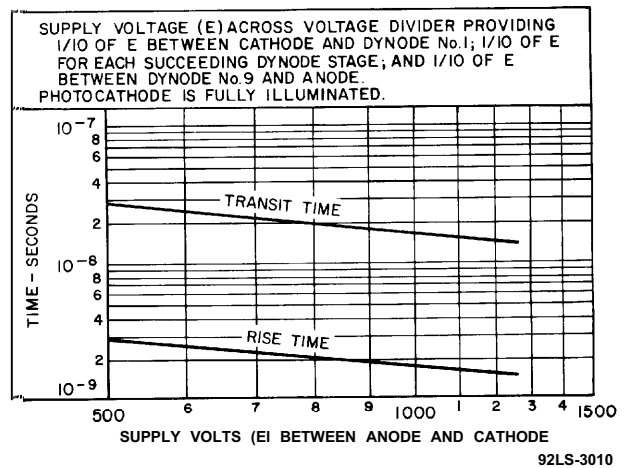
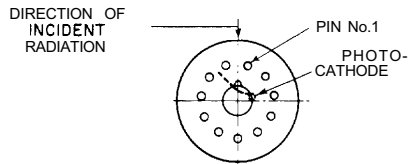
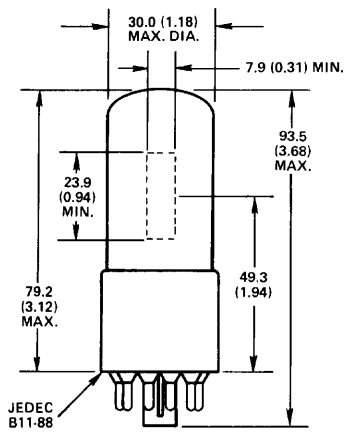

Figure 10 - Typical Time Characteristics



Dimensions in millimeters. Dimensions in parentheses are in inches.

- Note 1:** Envelope material is Corning No.0080, or equivalent. Its index of refraction at 436 nanometers is 1.52.
- Note 2:** Magnetic shielding of the tube is ordinarily required. Typical magnetic shield: BURLE AJ2240.
- Note 3:** Typical socket: BURLE AJ2256, or equivalent.

Figure 11 - Dimensional Outline

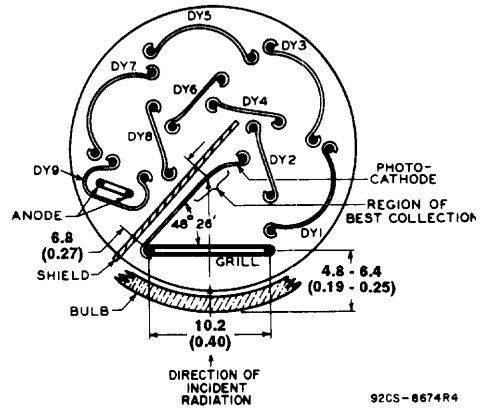

Dimensions in millimeters. Dimensions in parentheses are in inches.

Figure 12 - Construction Detail - Top View

- Pin 1: Dynode No.1
- Pin 2: Dynode No.2
- Pin 3: Dynode No.3
- Pin 4: Dynode No.4
- Pin 5: Dynode No.5
- Pin 6: Dynode No.6
- Pin 7: Dynode No.7
- Pin 8: Dynode No.8
- Pin 9: Dynode No.9
- Pin 10: Anode
- Pin 11: Photocathode

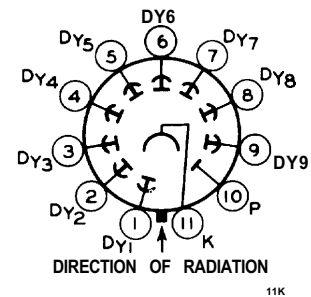

Figure 13 - Basing Diagram - Bottom View